



ANDAMIRO[®]
For Ultimate Happiness Of All



YEAR 2013
www.andamiro.com

1. About ANDAMIRO

GREETINGS

2. GAMES

[NEW GAMES]

- + FRUIT PARTY 2 **NEW**
- + FRUIT PARTY 1
- + COLOR BOYZ **NEW**
- + i - CUBE **NEW**
- + TOWER OF HANOI - DX **NEW**
- + GO STOP **NEW**

[DANCE FLOOR GAMES]

- + PUMP IT UP - FIESTA2
- + PUMP IT UP - INFINITY
- + PUMP IT UP CX
- + PUMP IT UP TX
- + PUMP JUMP

[REDEMPTION GAMES]

- + DINO FAMILY
- + TEETER TOTTER CASTLE
- + DOLPHIN SHOW
- + HAMMER2
- + ALL ABOARD

[MERCHANDISER]

- + WINNERS' RINGER
- + WINNERS' CUBE - SD
- + WINNERS' CUBE - DX
- + WINNERS' CUBE - CLASSIC

[SPORTS GAMES]

- + EN SHOOT
- + OVER THE TOP
- + KING OF THE HAMMER DX
- + DRAGON PUNCH
- + PENALTY SHOT

3. SALES CONTACT, ORDER AND SHIPPING

4. TECH SUPPORT & PARTS ORDERS

WELCOME TO **ANDAMIRO!!**



For over 21 years, Andamiro has grown into a company that provided a milestone of new dreams and happiness for all. We have been leading the frontline in the amusement and gaming industry ever since our establishment, and through the years, we have become a distinguished institution that has been acknowledged throughout the world.

We must not forget that we all live in time of continuous change, and trends become obsolete in a blink of an eye. Through our successful marketing relation and our focus on customer satisfaction, we have been able to grow exponentially in this most challenging times.

The development of technology has astonished the world market, especially in developing games.

We develop our games to not only provide personal enjoyment and satisfaction, but to spawn a new culture that incorporates our dreams and goals in the next generation.

This has changed the course of our industry's direction and we are proud to say, we have been a major contributor to the new cultural movement.

In the midst of a global financial crisis, we are dedicated to provide our partners, employees and customers our highest priority and unmatched service. Our integrity is never compromised and our vision to transform the world will be embedded in every aspect of our company. Now is the time to change the world and we invite you to be a part of our journey.



NEW
PRODUCT

水果屋1代的升级版《水果派对2代》

产品特点:

1. 使用固有专利（连续投币击中目标的游戏）
2. 场地必备产品
3. 无与伦比的营收
4. 跟前作相比，更容易，更有趣，更丰富的游戏功能
5. 多样化的派对奖励时间
6. 稳定的机率（平均彩票数）

玩法说明:

1. 请投币，击倒基座可获得相应彩票
2. 打亮五个幸运灯，可进入幸运彩金机会
3. 打亮五个金果灯，可进入X3~X?的金果派对时间
4. 打亮五个银果灯，可进入X3~X?的银果派对时间

SPECIFICATIONS

DIMENSIONS (W x D x H)	1416 X 1416 X 2226 (mm) 55.7 X 55.7 X 87.6 (Inch)
WEIGHT	370 kg
VOLTAGE	AC 220V
CONSUMPTION	280W



水果屋是把握机会投币后击中基座就可获得相应彩票的一款体感似的彩票机，旋转盘有不同票数的基座及奖励游戏，又刺激，又好玩，玩家可以乐在其中。

水果屋是一个具有代表性的彩票机，它可以连续投币的功能，之所以给场地创造高额利润及营收。机器共有4个控台，玩家可以在四处投币获得高额彩票分数，而且游戏也非常简单易懂，对于玩家来说是非常有益，有比较刺激的一款游戏。

还有一个特点是由一个玩家把灯大亮进入派对时间，这时其他玩家参与游戏，也有机会获得双倍奖金，所以适合于全年龄层，没有年龄限制。

水果屋的外观也非常华丽耀眼，而且炫耀的灯光及动听的音乐让这款机更加具有活力，在所有彩票机的行列中可以做一个领跑者的作用。

- 四个玩家可以同时挑战的游戏。
- 店主可以自行选择及设置平均彩票数
- 派对时间内有集体双倍分数功能
- 可编程性
- 华丽的外观设计

SPECIFICATIONS

DIMENSIONS (W x D x H)	1300 X 1300 X 2500 (mm) 51.2 X 51.2 X 98.4 (inch)
WEIGHT	303 kg
VOLTAGE	AC 110V / AC 220V
CONSUMPTION	400W



- 嘉年华的外观设计
- 随着电气化音乐魅力的LED灯光效果
- 简单易用照明按钮
- 功能强大，惊险刺激的跳球游戏体验
- 令人兴奋的和观看的乐趣
- 双分数，瞄球，通过运动目标
- 累积胜出的游戏让你上瘾

玩法说明：

- STEP01. 投币 (S) ;按下按钮准备发球
- STEP02. 当你通过一个彩色孔获得相应的彩票
- STEP03. 瞄球通过双得分移动目标
- STEP04. 避免进黑洞，并保持您的奖金
- STEP05. 目的是在一列中的所有五个灯点亮；RED列将中奖！



SPECIFICATIONS

DIMENSIONS (W x D x H)	996 X 986 X 2437 (mm) 39 X 37 X 96 (inch)
PACKING DIMENSIONS (W x D x H)	1150 X 1000 X 2190 (mm) 45.2 X 39.3 X 86.2 (inch)
WEIGHT	180 kg / 396.8 lbs
PACKING WEIGHT	205 kg / 452 lbs
VOLTAGE	AC 110V / AC 220V
FREQUENCY RANGE	60 Hz
CONSUMPTION	155W

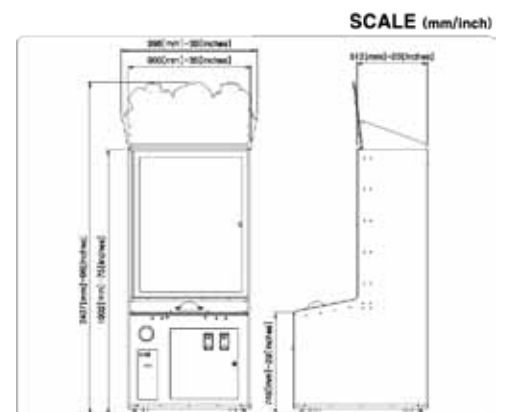



特点

- 坚固，灯光明亮，钢柜基础上美丽的独一无二设计！
- LED照明有炫丽的光彩！
- 用眼平视的游戏玩法，为玩家提供了获胜的信心！
- 防盗保护对于各项礼品！
- 大小礼品都可摆放！
- 简单的按钮控制！
- 每个礼品中奖机率都可调为1-9999！
- 可靠而又精准的赔率设置用步进电动机！

玩法说明：

- STEP01. 选择你想要奖金，瞄准相应的编号孔
- STEP01. 选择你想要奖金，瞄准相应的编号孔
- STEP02. 观察推杆移动。松放按钮，推进到预期的目标
- STEP03. 如“S”行推杆成功地穿过编号孔就可赢得大奖！



SPECIFICATIONS

DIMENSIONS (W x D x H)	984 X 950 X 1853 (mm) 38.7 X 37.4 X 73 (inch)
PACKING DIMENSIONS (W x D x H)	1150 X 850 X 2050 (mm) / 300 (kg) 45.2 X 33.4 X 80.7 (inch) / 661 (lbs)
WEIGHT (kg)	283 kg / 624 lbs
VOLTAGE	AC 110V / AC 110V
FREQUENCY RANGE	60 Hz
CONSUMPTION	180W

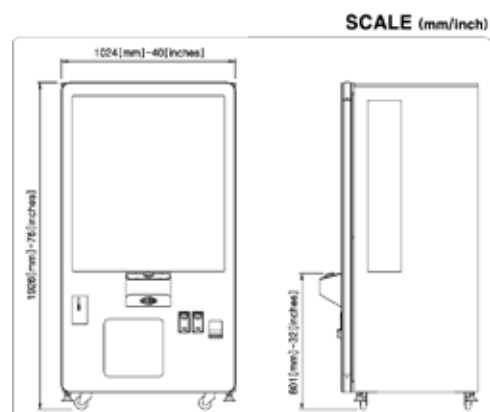



梵天之塔DX版本集成了一个非常令人上瘾而又简单的游戏。先进的3D物理引擎将带给玩家逼真的技能领奖游戏的感觉，而不是一个视频模仿。在玩游戏时，玩家将体验到逼真的3D对象和充满活力的运动感觉。凭借其迷人的电子音乐，令人非常满意的的游戏和迷人的外观，给场地创造更大的收入。

SPECIFICATIONS

DIMENSIONS (W x D x H)	1900 X 1320 X 1902 (mm)
WEIGHT	kg
VOLTAGE	AC 220V
FREQUENCY RANGE	50 Hz
CONSUMPTION	W



Easy and intuitive game play with traffic light concept. Ticket redemption game suitable for all ages. Simply press the button to stop the moving light at desired traffic light.

- Charismatic large traffic lights amplify the excitement of a player. Vibrant looks of the game makes it suitable for any location.
- Three games in triangular format will make a perfect centerpiece.
- Eye-catching familiar traffic light design makes the game to play for gigantic fun.

SPECIFICATIONS

DIMENSIONS (W x D x H)	1057 X 909 X 2284(mm) 41.6" X 35.8" X 89.9"
WEIGHT (kg)	132 kg / 291 lbs

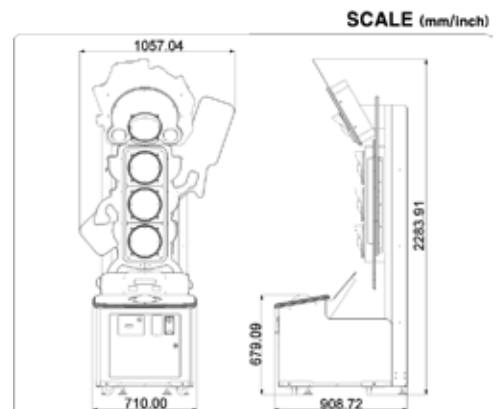



TX



CX



PIU2013 FIESTA 2 the latest software to upgrade PUMP IT UP (SX, DX, GX, FX, TX & CX) games that are in the field

- 450 songs, the largest collection in the history of PIU
- Total 3,000 more step charts!
- At least 60 new songs including popular K-POP , original songs and world music.
- Improved User Interface
 - Dual interface : More convenient interface for novices and experienced players
 - User-customized system : Various Customizing support by USB managing program, Pumbi.
 - User can play one's custom made steps by using USB
- Mission Mode : Simplified navigation makes it easier to access any mission
- High Score : More detailed individual player result

PUMP IT UP TX

Dimensions : (BODY) - W1472 X D821 X H2380 mm(57.9 X 32.3 X 93.7 inch)
 (STEP) : W1780 x D1103 x H93 mm(70 x 43.4 x 3.6 inch)
 Packing Dimension : W1878 x D2380 x H2424(73.9 x 93.7 x 95.4inch)
 Weight : (BODY) - 320 kg / 705 lbs (STEP) - 135 kg / 297.6 lbs

PUMP IT UP CX

Dimensions : (BODY) - W1213 X D753 X H2451 mm(47.7 X 29.6 X 96.4 inch)
 (STEP) : W1780 x D1103 x H93 mm(70 x 43.4 x 3.6 inch)
 Packing Dimension : W1400 x D900 x H2170(55.1 x 35.4 x 85.4 inch)
 Weight : (BODY) - 225 kg / 496 lbs (STEP) - 135 kg / 297.6 lbs



TX



CX



- 30+ New Songs! Over 400 In Total!
- Includes popular genres such as:
Hip Hop, Dubstep, Techno Drum 'n' Bass, Pop, and More!
- Four Unique Modes of Play
- Easy Mode for Beginners
- Arcade mode for all Players
- Music Train for Challengers
- Mission Mode for Enthusiasts
- Designed Specifically For Audiences in the United States and Europe.

PUMP IT UP TX

Dimensions : (BODY) - W1472 X D821 X H2380 mm(57.9 X 32.3 X 93.7 inch)

(STEP) : W1780 x D1103 x H93 mm(70 x 43.4 x 3.6 inch)

Packing Dimension : W1878 x D2380 x H2424(73.9 x 93.7 x 95.4inch)

Weight : (BODY) - 320 kg / 705 lbs (STEP) - 135 kg / 297.6 lbs

PUMP IT UP CX

Dimensions : (BODY) - W1213 X D753 X H2451 mm(47.7 X 29.6 X 96.4 inch)

(STEP) : W1780 x D1103 x H93 mm(70 x 43.4 x 3.6 inch)

Packing Dimension : W1400 x D900 x H2170(55.1 x 35.4 x 85.4 inch)

Weight : (BODY) - 225 kg / 496 lbs (STEP) - 135 kg / 297.6 lbs



Andamiro releases “Fiesta EX” the newest version of its extremely popular and Top Selling Dance Machine, Pump-It-Up CX 42” dance floor game.

SPECIFICATIONS

DIMENSIONS (W x D x H)	BODY	1213 x 753 x 2451 (mm) 47.7 x 29.6 x 96.4 (inch)
	STEP	1780 x 1103 x 93 (mm) 70 x 43.4 x 3.6 (inch)
PACKING DIMENSIONS (W x D x H)		1400 x 900 x 2170 (mm) 55.1 x 35.4 x 85.4 (inch)
WEIGHT (kg)	BODY	225 (kg) / 496 (lbs)
	STEP	135 (kg) / 297(lbs)
SCREEN SIZE		PDP 42”
POWER RATED VOLTAGE RANGE		AC 110V / AC 220V
POWER RATED FREQUENCY RANGE		50 Hz ~ 60 Hz
CONSUMPTION		600W / 600W

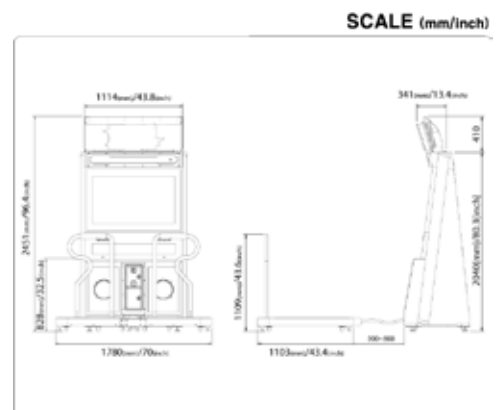



Pump It Up TX has a 50" Widescreen Display with newly advanced screen resolution and graphics. The TX 50" model features two high quality subwoofers and four tweeters to optimize audio performance that can easily impress any audiophile. Beat-synchronized LED Lights on the subwoofers draws players to the game.

SPECIFICATIONS

DIMENSIONS (W x D x H)	BODY	1472 x 821 x 2380 (mm) 57.9 x 32.3 x 93.7 (inch)
	STEP	1780 x 1103 x 93 (mm) 70 x 43.4 x 3.6 (inch)
PACKING DIMENSIONS (W x D x H)		1878 X 2380 X 2424 (mm) 73.9 x 93.7 x 95.4 (inch)
WEIGHT (kg)	BODY	320 (kg) / 705 (lbs)
	STEP	135 (kg) / 297.6 (lbs)
SCREEN SIZE		PDP 50"
POWER RATED VOLTAGE RANGE		AC 110V / AC 220V
POWER RATED FREQUENCY RANGE		50 Hz ~ 60 Hz
CONSUMPTION		1200W / 1200W

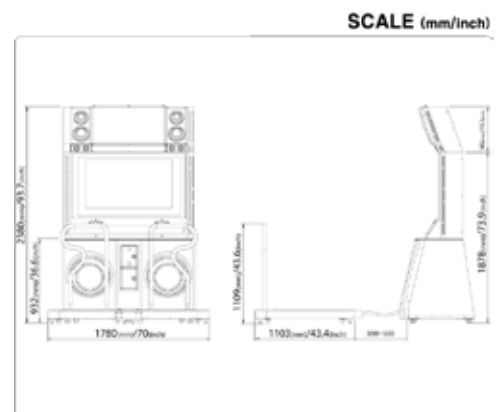



With the continued success of the long running Pump-It-Up series, Andamiro introduces Pump Jump, the world's finest dance simulation game geared towards kids. The game combines fun with exert fitness.

Physical dimensions of the Pump It Up Jump have been heavily modified and compressed to accommodate and attract younger players.

SPECIFICATIONS

DIMENSIONS (W x D x H)	BODY	1392 x 668 x 2070 (mm) 54.8 x 26.2 x 81.4 (inch)
	STEP	1600 x 1049 x 814 (mm) 62.9 x 41.2 x 32 (inch)
PACKING DIMENSIONS (W x D x H)	BODY : 1150 x 970 x 1610 (mm) 45.2 x 38 x 63.3 (inch) STEP : 1290 x 1020 x 270 (mm) 50.7 x 40.1 x 10.6(inch)	
WEIGHT (kg)	250 (kg) / 551(lbs)	
SCREEN SIZE	LCD 32"	
POWER RATED VOLTAGE RANGE	AC 110V, 220V	
SPEAKER	8" WOOFER -1ea / 60W MID 4" - 2ea / 40W	
CONSUMPTION	550W	

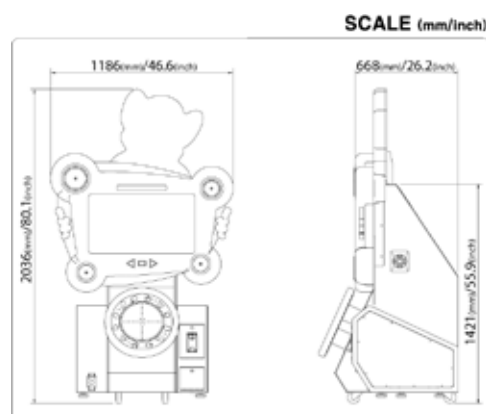



A cute dinosaur spawning a golf ball
 Timely release of golf ball will help ball drop into targeted hole
 Game of skill; Fun to play;
 Suitable for all ages
 Rotating playfield with holes marked with different ticket values

- Cute Dino family Thematic Design
- Exciting & Intuitive Game Play
- Operator-Friendly & Easy to Maintain



SPECIFICATIONS

DIMENSIONS (W x D x H)	1092 X 1265 X 2036(mm) 39.6" X 91.9" X 98.4"
PACKING DIMENSIONS (W x D x H)	-- X -- X --
WEIGHT (kg)	200 kg / 440 lbs
VOLTAGE	AC 110V / AC220V
FREQUENCY RANGE	50 ~ 60 Hz
CONSUMPTION	170W

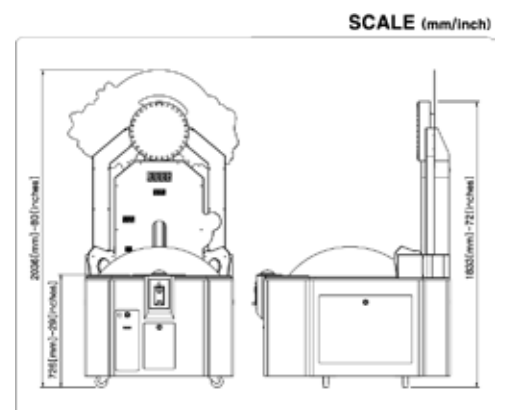



Teeter Totter Castle is a video redemption game of skill suitable for all ages, with both fun and intuitive gameplay.

An advanced 3D Physical Graphics Engine will Give players the feel of a real skill redemption game, rather than a video imitation. Players will experience realistic 3D objects and vibrant movements while playing the game.

Teeter Totter Castle exhibits a child + family friendly cabinet design. The game comes with easy setup, and achieves payout stability by using a reliable high-tech system.



SPECIFICATIONS

DIMENSIONS (W x D x H)	984 x 950 x 1853 (mm) 38.7 x 37.4 x 72.9 (inch)
PACKING DIMENSIONS (W x D x H)	1150 x 1080 x 2140 (mm) 45 x 42.5 x 84.2 (inch)
DISPLAY	LCD 32"
WEIGHT (kg)	130 kg (PACKAGING 150kg) 286 lbs (PACKAGING 330 lbs)
VOLTAGE	AC 120V / AC 220V
FREQUENCY RANGE	60 Hz / 60 Hz
CONSUMPTION	300W / 310W

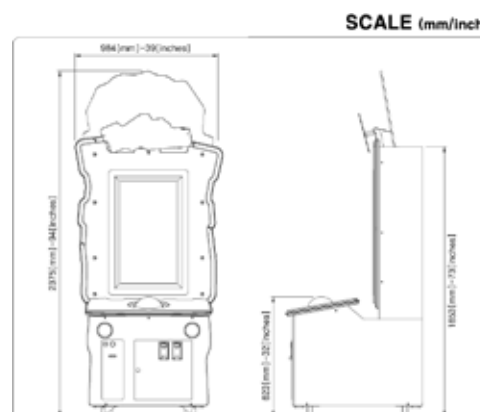



Dolphin Show is one awesome redemption game that maintains an unforgettable experience for players, while rewarding high profits for its operators. The objective of Dolphin Show is very simple and straightforward as players will timely launch the colored ball into a rotating playfield which has holes with different ticket values. This simple game of skill is

suitable for all ages. Player's will play for a prior set of number of free plays that is offered when all words are lit to spell 'DOLPHIN'. The aggregate number of tickets earned during free plays will be the grand winning that the player receives.



SPECIFICATIONS

DIMENSIONS (W x D x H)	1100 x 1019 x 1593 (mm) 43.3 x 40.1 x 62.7 (inch)
PACKING DIMENSIONS (W x D x H)	1150 x 1080 x 1790 (mm) 45.2 x 42.5 x 70.4 (inch)
WEIGHT (kg)	200 kg (PACKAGING 208 kg) 440 lbs (PACKAGING 458.5 lbs)
VOLTAGE	AC 110V / AC 220V
FREQUENCY RANGE	60 Hz / 60 Hz
CONSUMPTION	300W

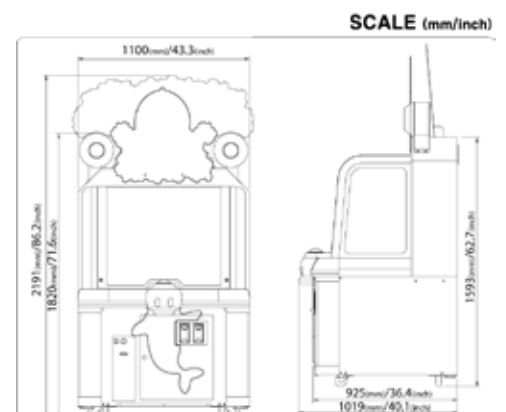



Hammer 2 is a family friendly designed game where players simply pick up a mallet to smash and pound on targets.

Players can play up to three stages per play of 40 seconds each, with increasing difficulty as the game continues.

The system allows players to challenge other players in a head-to-head competition.

Hammer2 has provided steady income to date at every family entertainment center it resides.

SPECIFICATIONS

DIMENSIONS (W x D x H)		1360 x 1113 x 1938 (mm) 53.5 x 43.8 x 76.2 (inch)
PACKING DIMENSIONS (W x D x H)		1498 x 1140 x 1295 (mm) / 208 (kg) 58.9 x 44.8 x 50.9 (inch) / 458.5 (lbs)
DISPLAY		PDP 42"
WEIGHT (kg)	CASE	150 kg
	BILLBOARD	50KG
VOLTAGE		AC 110V / 220V
FREQUENCY RANGE		50 Hz ~ 60 Hz
CONSUMPTION		800W

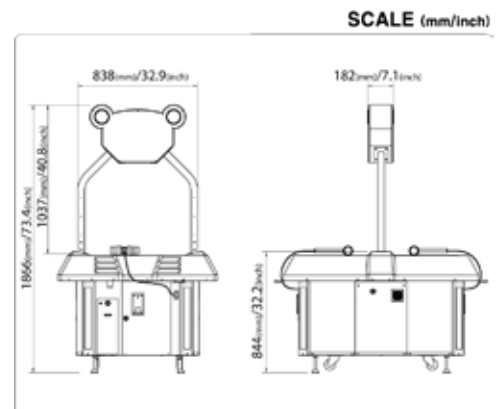



All Aboard features a locomotive design theme and family friendly sound package which delivers exciting captivating tunes.

All Aboard is available for every family entertainment center that is looking for an exciting new attraction.

LED lit transparent display buttons deliver a realistic feel and enhances game play experiences.



SPECIFICATIONS

DIMENSIONS (W x D x H)	1355 x 1192 x 2374 (mm) 53.3 x 46.9 x 93.4 (inch)
WEIGHT (kg)	222 (kg) / 489.4 (lbs)
VOLTAGE	AC 120V / AC 220V
FREQUENCY RANGE	50 Hz ~ 60 Hz
CONSUMPTION	230W

SCALE (mm/inch)

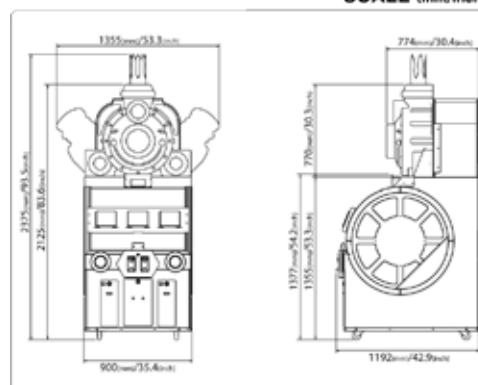



- Sturdy, Brightly Lit, Steel Cabinet Based on Beautiful iPhone Design !
- LED Lighting For Charismatic Look !
- Eye Level Play Zone Gives Players Confidence Of Winning !
- Anti-Theft Protection For Each Prize Bin !
- Adjustable Prize Bins To Hold Various Size Prizes !
- Simple 1 Button Control !
- Each Prize Bin Is Adjustable For Payout From 1~9999 !
- Reliable & Accurate Payout Setting By Using Stepping Motor Mechanism !



SPECIFICATIONS

DIMENSIONS (W x D x H)	984 X 950 X 1853 (mm) 38.7 X 37.4 X 73 (inch)
PACKING DIMENSIONS (W x D x H)	1150 X 850 X 2050 (mm) / 300 (kg) 45.2 X 33.4 X 80.7 (inch) / 661 (lbs)
WEIGHT (kg)	283 kg / 624 lbs
VOLTAGE	AC 110V / AC 110V
FREQUENCY RANGE	60 Hz
CONSUMPTION	180W

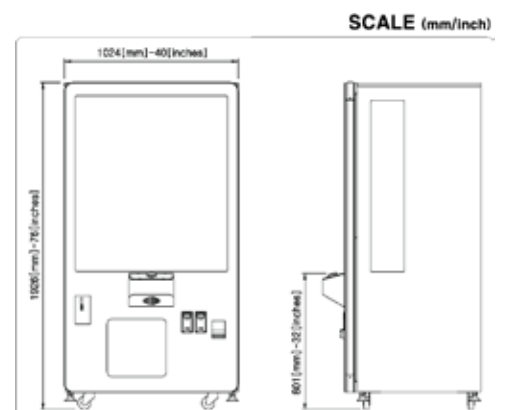



Winners Ringer incorporates an extremely addictive and simplistic game play.

With its captivating digital music, highly gratifying gameplay and mesmerizing looks, this game will prove to be a big moneymaker in any location.

The advanced 3D Physical Engine will give players the feel of realistic skill prize redemption game, rather than a video imitation. Players will experience realistic 3D objects and vibrant movements while playing the game.



SPECIFICATIONS

DIMENSIONS (W x D x H)	984 x 855 x 1902 (mm) 38.7 x 33.6 x 74.8 (inch)
PACKING DIMENSIONS (W x D x H)	1140 x 790 x 2150 (mm) 44.8 x 31.1 x 84.6 (inch)
WEIGHT (kg)	225 kg (PACKAGING 260 kg) 496 lbs (PACKAGING 573 lbs)
VOLTAGE	AC 110V / AC 220V
FREQUENCY RANGE	50 Hz ~ 60 Hz
CONSUMPTION	400W

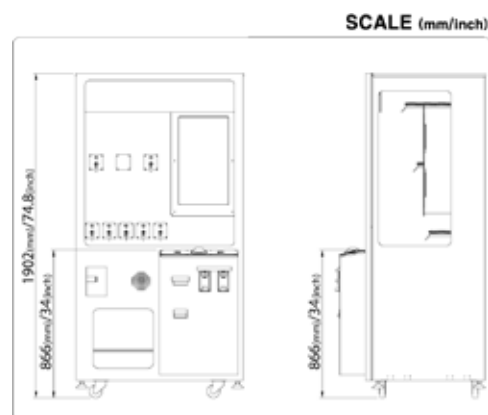



The luxurious exterior design and brilliant interior lighting makes the Winners' Cube the ultimate attraction that will bring profits in a wide variety of locations.

Prizes are displayed in a gigantic transparent display with bright white lights to illuminate the prize shelves providing a glamorous and sleek look.

SPECIFICATIONS

DIMENSION (W x D x H)	995 x 930 x 1820 (mm) 39 x 36.6 x 71.6 (inch)
PACKING DIMENSIONS (W x D x H)	1150 x 850 x 1910 (mm) 45.2 x 33.4 x 75.1 (inch)
WEIGHT (kg)	243 kg (PACKAGING 250 kg) 535.7 lbs (PACKAGING 551 lbs)
VOLTAGE	AC 110V / AC 220V
FREQUENCY RANGE	50 Hz ~ 60 Hz
CONSUMPTION	280W / 200W

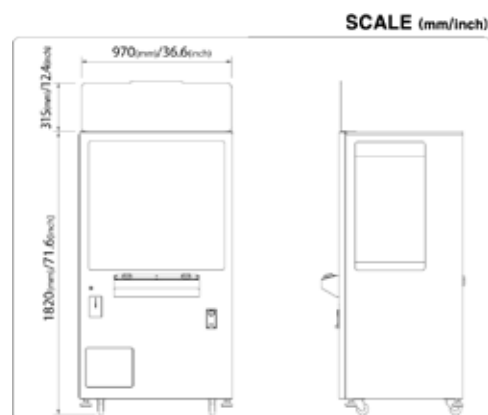



The luxurious exterior design and brilliant interior lighting makes the Winners' Cube the ultimate attraction that will bring profits in a wide variety of locations.

Prizes are displayed in a gigantic transparent display with bright white lights to illuminate the prize shelves providing a glamorous and sleek look.

SPECIFICATIONS

DIMENSIONS (W x D x H)	1720 x 1123 x 1940 (mm) 67.7 x 44.2 x 76.3 (inch)
PACKING DIMENSIONS (W x D x H)	1800 x 1150 x 2150 (mm) 70.8 x 45.2 x 84.6 (inch)
WEIGHT (kg)	300 kg (PACKAGING 400 kg) 661 lbs (PACKAGING 881 lbs)
VOLTAGE	AC 110V
FREQUENCY RANGE	60 Hz
CONSUMPTION	360W

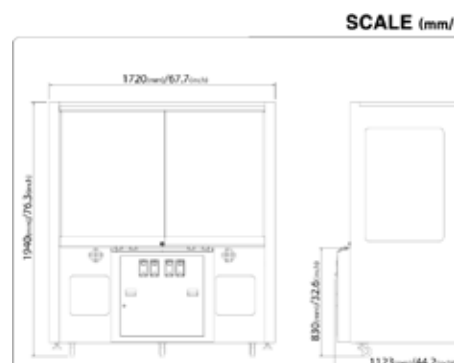



The luxurious exterior design and brilliant interior lighting makes the Winners' Cube the ultimate attraction that will bring profits in a wide variety of locations.

Prizes are displayed in a gigantic transparent display with bright white lights to illuminate the prize shelves providing a glamorous and sleek look.

SPECIFICATIONS

DIMENSIONS (W x D x H)	600 x 780 x 1820 (mm) 23.6 x 30.7 x 71.6 (inch)
PACKING DIMENSIONS (W x D x H)	760 x 840 x 1940 (mm) 29.9 x 33 x 76.3 (inch)
WEIGHT (kg)	200 kg (PACKAGING 208 kg) 440 lbs (PACKAGING 458 lbs)
VOLTAGE	AC 110V / AC 220V
FREQUENCY RANGE	50 Hz / 60 Hz
CONSUMPTION	200W

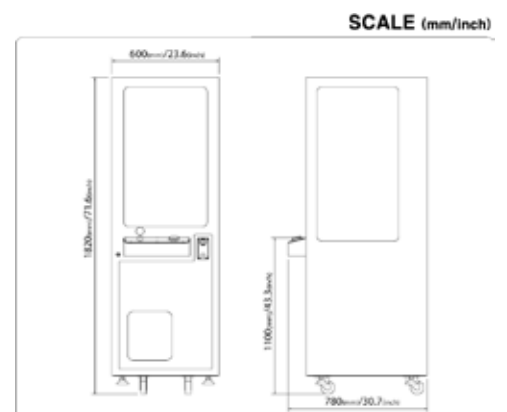



- LED Lighting Effect On The Billboard.
- Sound System Equipped With Woofers.
- Halftime Show On Display.
- Foldable Structure For Easy Shipping.
- Two Types Of Very Attractive Graphics.
- Special Sensors For SWISH And MONEY BALL (Patent Pending).



SPECIFICATIONS

DIMENSIONS (W x D x H)	1006 X 2335 X 2501(mm) 39.6" X 91.9" X 98.4"
PACKING DIMENSIONS (W x D x H)	-- X -- X --
WEIGHT (kg)	250 kg / 551 lbs
VOLTAGE	AC 220V
FREQUENCY RANGE	50 Hz
CONSUMPTION	300W

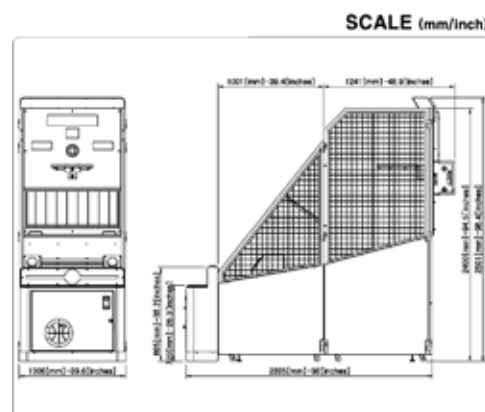



One of the games “OVER THE TOP” a traditional arm wrestling game has very interesting and exclusive features. “OVER THE TOP” uplifting & stylish arm wrestling game has innovative clutch motor mechanism and smart-logic safety system. Players have choice to choose their preferable opponent matching their strength.

The game is operator-friendly and is very easy to maintain. All reinforced steel construction of the game cabinet makes “OVER THE TOP” a very durable. The game is equipped with ticket payout feature as well.

SPECIFICATIONS

DIMENSIONS (W x D x H)	740 x 1150 x 2060 (mm) 29.1.6 x 45.2 x 81.1 (inch)
PACKING DIMENSIONS (W x D x H)	900 x 1300 x 2100 (mm) / 210 kg
WEIGHT (kg)	180 kg / 397 lbs
VOLTAGE	AC 110V / AC 220V
FREQUENCY RANGE	50Hz
CONSUMPTION	



DX



SD

King of the Hammer comes in two models, Midway (SD) and Deluxe (DX) model. Both models are wired to accept ticket dispensers.

Traditional midway (SD) has an accurate power gauge with 30 LED sets of 70 LED light bulbs each.

The Deluxe (DX) version has an extended power gauge with 60 LED sets of 70 LED light bulbs each.

This traditional but smaller-sized carnival hammer game comes in both ticket (redemption mode) and also prize mode, and is waterproof so it is suitable for all locations.

SPECIFICATIONS(DX)

DIMENSIONS(W x D x H)	785 x 900 x 3500 (mm) 30.9 x 35.4 x 137.7 (inch)
PACKING DIMENSIONS (W x D x H)	1016 x 2438 x 1245 (mm) 40 x 95.9 x 49 (inch)
WEIGHT (kg)	326 kg (718 lbs)
VOLTAGE	AC 110V / AC 220V
FREQUENCY RANGE	50 Hz / 60 Hz
CONSUMPTION	250W

SPECIFICATIONS(SD)

DIMENSIONS (W x D x H)	550 x 900 x 2350 (mm) 21.6 x 35.4 x 92.5 (inch)
PACKING DIMENSIONS (W x D x H)	1016 x 1220 x 1245 (mm) 40 x 48 x 49 (inch)
WEIGHT (kg)	222 kg (489.4 lbs)
VOLTAGE	AC 110V / AC 220V
FREQUENCY RANGE	50 Hz / 60 Hz
CONSUMPTION	250W

DRAGON PUNCH



Dragon Punch is equipped with a big electronic display showing the score of each punch. During the game, every participant can see and compare his/her result with the top score on the separate digital display.

The Dragon Punch Boxing Machine features a Urethane Cushion Pad for extra safety and a Waterproof Finishing for Outdoor use. Dragon Punch game has produced profits in a wide variety of locations, including bars, nightclubs & FEC's.



SPECIFICATIONS

DIMENSIONS (W x D x H)	830 x 1115 x 2220 (mm) 32.6 x 43.8 x 87.4 (inch)
PACKING DIMENSIONS (W x D x H)	1067x 1220x 2160 (mm) / 204 (kg) 42 x 48 x 85 (inch) / 449.7 (lbs)
WEIGHT (kg)	120 kg / 264.5 lbs
VOLTAGE	110V / 220V
FREQUENCY RANGE	50 Hz / 60 Hz
CONSUMPTION	(approx)80W



Penalty Shot is brilliantly designed with energetic colors and a splendid LED lighting system that delivers an uncompromising, charismatic presence in any environment.

With superb sound quality along with its attractive decor, Penalty Shot offers its players to experience a glimpse of glory where only soccer superstars display.

SPECIFICATIONS

DIMENSIONS (W x D x H)	900 x 1100 x 1980 (mm) 35.4 x 43.3 x 77.9 (inch)
PACKING DIMENSIONS (W x D x H)	1376 x 1219 x 1370 (mm) 54.1 x 47.9 x 53.9 (inch)
WEIGHT (kg)	160 kg (PACKAGING 257 kg) 352.7 lbs (PACKAGING 566.5 lbs)
VOLTAGE	AC 110V / AC 220V
FREQUENCY RANGE	50 Hz / 60 Hz
CONSUMPTION	800W

We at Andamiro sell our products in over 70 different countries around the globe.

We provide customers with reasonable prices and better quality for their valued inquiries.

Our sales team is not only here to sell, but also act as consultants to help each customer maximize in their profit margins.

Andamiro assures its customers of services to their utmost satisfaction.

NORTH AMERICA

Mr. Satinder K. Bhutani
Tel. 1-310-767-5800 (ext. 102)
satinb@andamirousa.com

**MEXICO,
CENTRAL & SOUTH AMERICA**

Mr. Samuel Kim
Tel. 82-31-909-2051
morandes@andamiro.com

ASIA

Mr. Leo Kim
Tel. 82-31-909-2124
leokim@andamiro.com

CHINA

Mr. Jacky Lin
Tel. 020-3925-9297
jackylin@andamiro.com

EUROPE

Mr. Joshua Kim
Tel. 82-31-909-2123
joshua@andamiro.com

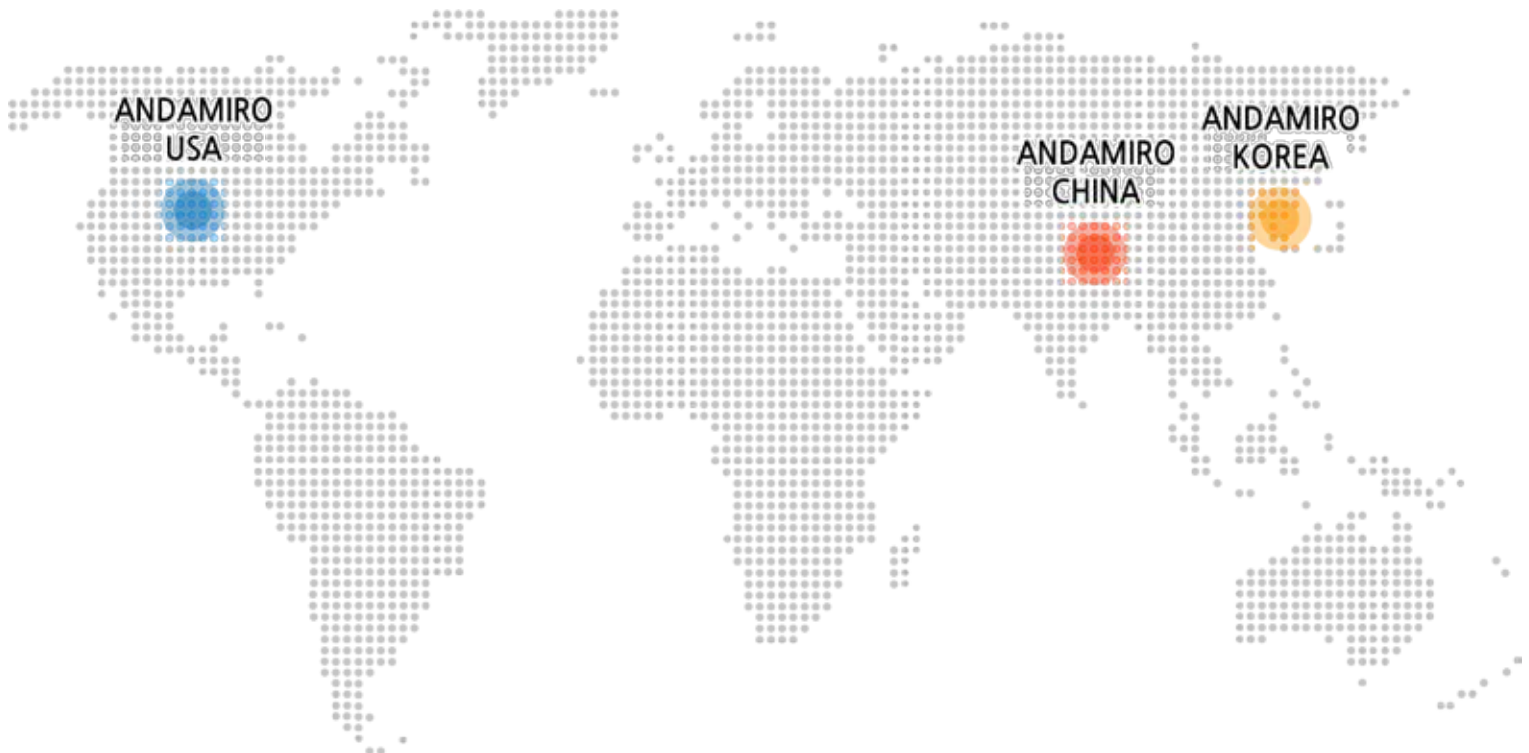



Our commitment to product quality and reliability as well as after sales parts and service is unparalleled.

Our Customer service division provides a full line of replacement parts and service for all of the items we carry and are ready to help you with problems over the phone or email.

Tech Support - Headquarters in Korea

MEXICO, CENTRAL & SOUTH AMERICA

Mr. Samuel Kim
Tel. 82-31-909-2051
morandes@andamiro.com

EUROPE

Mr. Joshua Kim
Tel. 82-31-909-2123
joshua@andamiro.com

ASIA

Mr. Leo Kim
Tel. 82-31-909-2124
leokim@andamiro.com

Tech Support in America

Jose F. Jimenez

Tel. 310-767-5800 ext. 106
E-Mail to: service@andamirousa.com



TOP

.....

.....

.....

.....

.....

.....

.....

.....

.....

.....

.....

.....

.....

.....

.....

.....

.....

.....

.....

.....

.....



WWW.ANDAMIRO.COM

ANDAMIRO

6006 M-City Tower, 869 Changhang-dong, Ilsandong-gu,
Koyang-si, Kyonggi-do, 410-837, Korea
Tel. 82-31-909-2121 Fax. 82-31-908-7548
sales@andamiro.com

ANDAMIRO USA

17230 Main St, Carson, Los Angeles,
California, U.S.A
Tel. 1-310-767-5800 Fax. 1-310-767-5805
sales@andamirousa.com